



JFE

# JFE EVERHARD

JFE-EH Series

Abrasion-Resistant Steel Plate

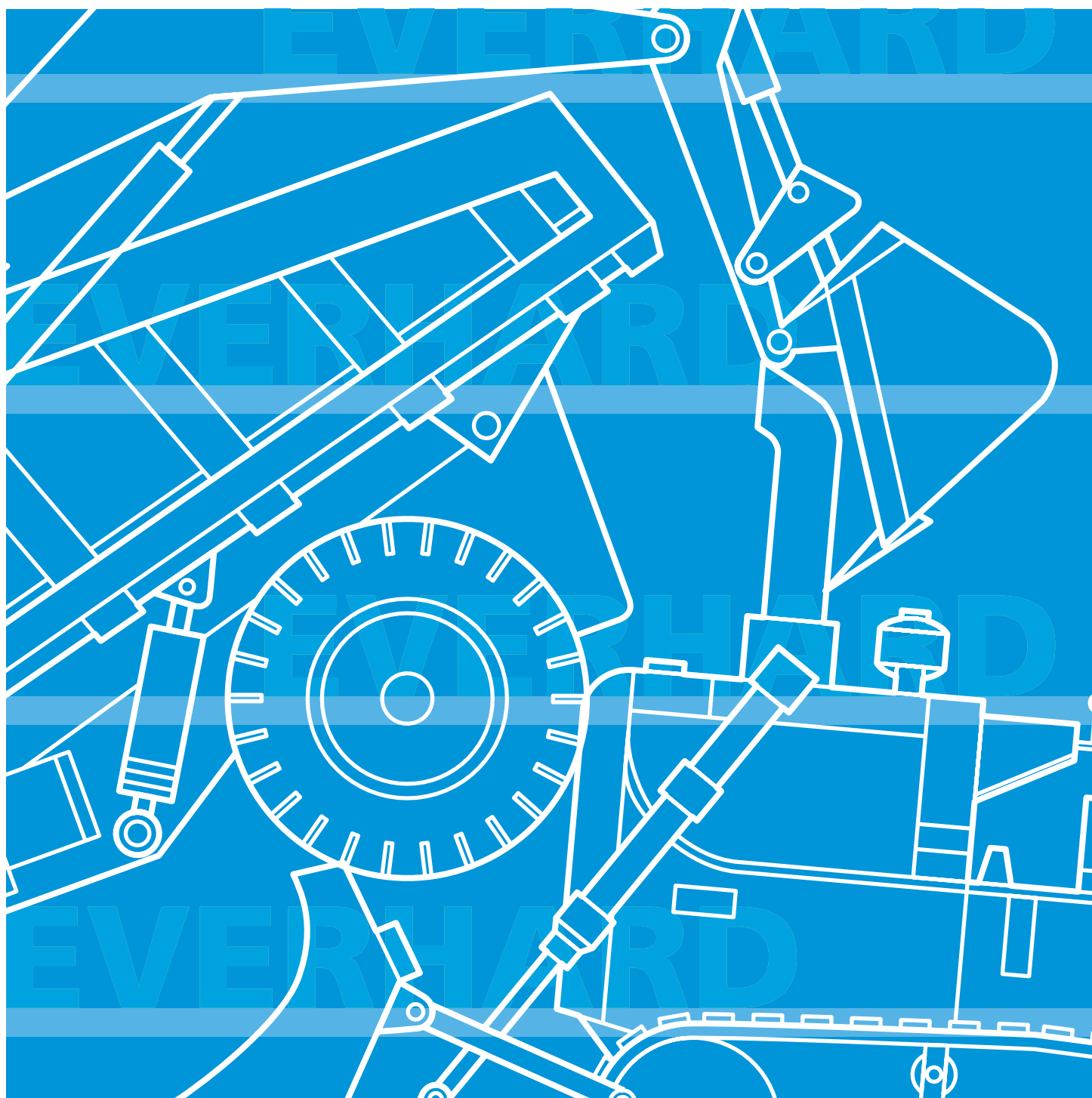

JFE Steel Corporation

## Contents

Special Features of JFE EVERHARD .....	2
Specifications of JFE EVERHARD .....	3
Typical Mechanical Properties of JFE EVERHARD .....	4
Maximum Available Sizes .....	5
Typical Applications .....	6
Recommendations for excellent fabrication performance .....	7

JFE  
Steel Co.

pioneered the production and sale of abrasion-resistant steel plate in Japan in the mid-1950s, and JFE abrasion-resistant steel plate (JFE EVERHARD) enjoyed widespread use as a vital material for construction, mining, civil engineering and farming equipment.

Furthermore, JFE Steel Co. has succeeded in developing super abrasion-resistant steel plate EH-SP with higher abrasion-resistance than that of the Brinell 500 grade, and EH360LE, EH500LE with excellent toughness through the leading edge of production technology. Those products enjoy customer's reputation.

In this catalog, we would like to introduce the JFE EVERHARD series of abrasion-resistant steel plate.

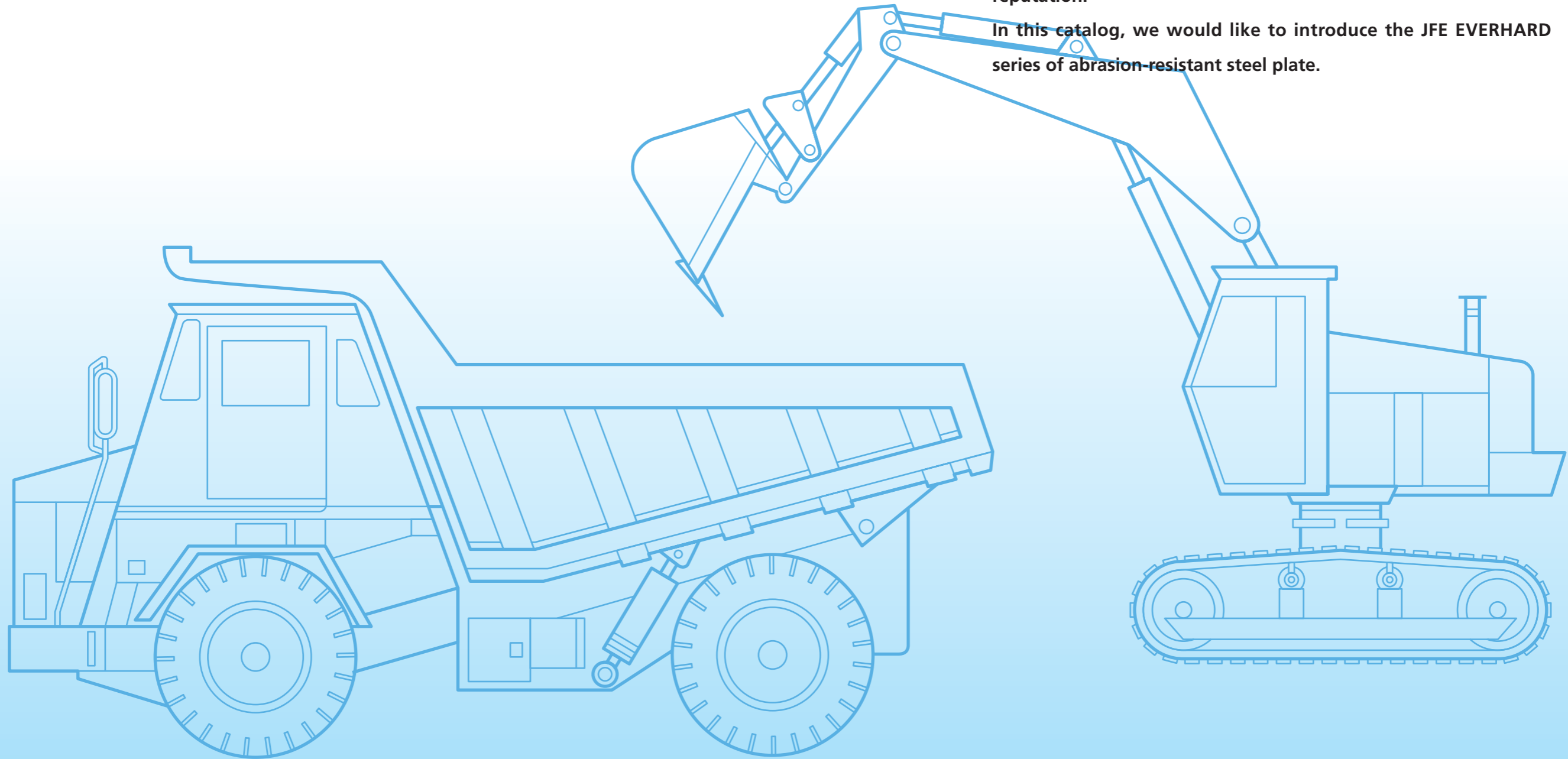



# Special Features of JFE EVERHARD

## A variety of available grades

A total of 8 grades are available ; the standard series and the alloy series with 3 and 2 grades of hardness respectively, a new super abrasion resistant grade, as well as 360 grade and 500 grade with high toughness, providing a complete product line that can meet a wide range of applications.

### Standard Series

This series consists of grades produced with the main emphasis on their hardness levels, the chemical composition being basically simple with boron added while the addition of other alloying elements is restrained.

### Alloy Series

This series contains alloying elements in greater quantities than the standard series. The prescribed hardness is guaranteed for plate thickness of up to 100mm and, at the same time, careful consideration has been given to low-temperature toughness.

### Super Abrasion resistant plate EH-SP

Customers often call for the development of a longer-lasting abrasion-resistant plate in order to reduce running cost. However up to now, it has been difficult to develop an abrasion resistant plate that performs better than the conventional 500 grade plate, without reducing the plate's weldability and formability.

Our new higher abrasion resistant plate succeeds in doing this.

## Abrasion-resistant steel plate with excellent toughness EH360LE, EH500LE

High toughness at -40°C of abrasion-resistant steel plate was generally difficult to be guaranteed.

JFE has succeeded in developing abrasion-resistant steel plate including 500 grade with excellent toughness guaranteed at -40°C. EH360LE and EH500LE are the most suitable plates when high toughness is required because of the application in low temperature environment and/or suffering with high impact.

EH360LE has also high resistance to weld cracking, then presents high quality and safety of welded joint.

## Superb quality

JFE's abrasion-resistant steel plates are produced at modern Works. Based on many years of experience, production incorporates the latest in heat treatment technology and proceeds under strict quality control. The result is high-quality steel plate that offers not only outstanding abrasion-resistance but good weldability and workability as well.

# Specifications of JFE EVERHARD

JFE EVERHARD is manufactured for non-structural steel plates which are specified by chemical analysis of molten steel, Brinell hardness at the plate surface and material toughness. It is not specified and guaranteed by its tensile strength and elongation which are required to be specified as structural steel plates. In case of any request for the tensile strength and/or elongation as reference, please refer to JFE Steel Technical Bulletins.

## 1. Chemical composition

Type	Grade	Available thickness mm	Heat treatment	Chemical composition %*										
				C	Si	Mn	P	S	Cr	Mo	V	Ti	B	Ceq**
Standard	JFE-EH360	6~50	Controlled Heat Treatment	0.20max.	0.55 max.	1.60 max.	0.030 max.	0.030 max.	0.40max.	—	—	0.005 ~0.020	0.004 max.	—
	JFE-EH400			0.25max.					0.80max.					
	JFE-EH500			0.35max.					0.80max.					
Alloyed	JFE-EH360A	6~100	Controlled Heat Treatment	0.20max.	0.55 max.	1.60 max.	0.030 max.	0.030 max.	0.40	0.10 ~0.50	0.10 max.	0.020 max.	0.004 max.	—
	JFE-EH500A			0.35max.					~1.20					
	JFE-EH-SP	6~65	Controlled Heat Treatment	0.35max.	0.55max.	1.60max.	0.030 max.	0.030 max.	0.50 ~1.50	Other alloying elements are added.				
	JFE-EH360LE	6~19	Controlled Heat Treatment	0.17 max.	0.55 max.	1.60 max.	0.020 max.	0.010 max.	0.40 max.	0.35 max.	—	0.020 max.	0.004 max.	0.40max.
		19.1~32		0.43max.										
	JFE-EH500LE	6~19	Controlled Heat Treatment	0.29 max.	0.55 max.	1.60 max.	0.020 max.	0.010 max.	0.40 max.	0.35 max.	—	0.020 max.	0.004 max.	0.55max.
		19.1~32												0.58max.

\*Elements that are not given in the above table may be added. Chemical composition data are quoted from our molten steel analysis.

\*\*Ceq = C + Mn / 6 + (Cu + Ni) / 15 + (Cr + Mo + V) / 5

## 2. Mechanical properties

Type	Grade	Hardness test*		Charpy impact test		
		Thickness mm	Brinell hardness (3000) (Average of 5 values)	Thickness mm	Test temperature °C	Impact value J (Average of 3 specimens)
Standard	JFE-EH360	6~50	361min.	—	—	—
	JFE-EH400	6~50	401min.	—	—	—
	JFE-EH500	6~50	477min.	—	—	—
Alloyed	JFE-EH360A	6~100	361min.	13.1~50.0	0	21min.
	JFE-EH500A	6~100	477min.	13.1~25.0	0	21min.
	JFE-EH-SP	6~65	401min.	—	—	—
	JFE-EH360LE	6~32	361~440	12.0~32.0	-40	27min.
	JFE-EH500LE	6~32	477~556	12.0~32.0	-40	21min.

\*Test for plate surface.

## 3. Appearance, shape, dimensions, mass and their tolerances comply with JIS G3193.

# Typical Mechanical Properties of JFE EVERHARD

Grade	Thick- ness mm	Mechanical properties										
		Tensile test					Bend test			Charpy impact test		Hardness test
		Test specimen	Sampling direction	Yield strength N/mm <sup>2</sup>	Tensile strength N/mm <sup>2</sup>	Elongation %	Test specimen	Sampling direction	Bend radius =thickness × 3	Sampling direction	Impact value 0°C Average J	Brinell hardness (3000) Average of 5 values
JFE-EH360	19	JIS-5	C	1083	1246	20.8	JIS-1	L	Good	—	—	385
JFE-EH400	19	JIS-5	C	1163	1316	19.8	JIS-1	L	Good	—	—	442
JFE-EH500	19	JIS-5	C	1297	1449	17.7	JIS-1	L	Good	—	—	508
JFE-EH360A	19	JIS-5	C	1147	1203	23.9	JIS-1	L	Good	L	156	388
JFE-EH500A	20	JIS-5	C	1321	1516	22.9	JIS-1	L	Good	L	65	542
JFE-EH-SP	35	JIS-5	C	1104	1352	10.7	JIS-1	L	Good	—	—	455
JFE-EH360LE	19	JIS-5	C	1058	1308	23.0	JIS-1	L	Good	L	−40°C 61	411
JFE-EH500LE	20	JIS-5	C	1203	1681	17.0	JIS-1	L	Good	L	−40°C 42	502

# Maximum Available Sizes

Product length : m

Thickness mm	Width mm	1501	1801	2001	2201	2401	2601	2801	3001	3201	3401	3601	3801	4001	4201	4401	4601	4801	5001	5201
		1800	2000	2200	2400	2600	2800	3000	3200	3400	3600	3800	4000	4200	4400	4600	4800	5000	5200	5300
6.0 ~ 6.9	6.9	18	16	14	12	12	10	—	—	—	—	—	—	—	—	—	—	—	—	—
7.0 ~ 7.9	7.9	18	16	14	12	12	10	—	—	—	—	—	—	—	—	—	—	—	—	—
8.0 ~ 8.9	8.9	18	16	14	12	12	10	—	—	—	—	—	—	—	—	—	—	—	—	—
9.0 ~ 9.9	9.9	18	16	14	12	12	10	—	—	—	—	—	—	—	—	—	—	—	—	—
10.0 ~ 11.9	11.9	22	20	18	16	14	14	12	—	—	—	—	—	—	—	—	—	—	—	—
12.0 ~ 12.9	12.9	22	20	18	16	14	14	12	—	—	—	—	—	—	—	—	—	—	—	—
13.0 ~ 13.9	13.9	22	20	18	16	14	14	12	—	—	—	—	—	—	—	—	—	—	—	—
14.0 ~ 22.0	22.0	22	20	18	16	14	14	12	—	—	—	—	—	—	—	—	—	—	—	—
22.1 ~ 24.0	24.0	24	22	22	20	18	16	14	12	—	—	—	—	—	—	—	—	—	—	—
24.1 ~ 26.0	26.0	25	24	22	22	20	18	16	14	12	—	—	—	—	—	—	—	—	—	—
26.1 ~ 28.0	28.0	25	25	24	24	22	22	20	18	16	14	12	—	—	—	—	—	—	—	—
28.1 ~ 30.0	30.0	25	25	25	25	25	24	22	20	20	18	18	16	16	—	—	—	—	—	—
30.1 ~ 35.0	35.0	25	25	25	25	25	25	24	22	22	22	20	20	20	18	18	18	—	—	—
35.1 ~ 40.0	40.0	25	25	25	25	25	25	25	24	22	22	22	20	20	20	19	18	—	—	—
40.1 ~ 45.0	45.0	25	25	25	25	25	25	25	25	24	23	22	20	19	19	18	17	16	16	—
45.1 ~ 50.8	50.8	25	25	25	25	25	25	25	23	22	20	20	18	17	17	16	15	15	14	—
50.9 ~ 60.0	60.0	25	23	23	21	24	22	20	19	18	17	16	15	14	14	13	13	12	11	—
60.1 ~ 70.0	70.0	22	19	20	18	20	19	17	16	15	14	14	13	12	12	11	11	10	10	—
70.1 ~ 80.0	80.0	19	17	17	16	18	16	15	14	13	13	12	11	11	10	10	9.7	9.3	8.9	—
80.1 ~ 90.0	90.0	17	15	15	14	16	14	13	13	12	11	11	10	9.8	9.4	8.9	8.6	8.2	7.9	—
90.1 ~ 100.0	100.0	15	13	14	12	14	13	12	11	10	10	10	9.3	8.8	8.4	8.0	7.7	7.4	7.1	—



# Typical Applications

Industry	Applications
<p><b>Construction and Automotive Industries</b></p>	<ul style="list-style-type: none"> <li>● Bulldozer shovels and buckets</li> <li>Slush plates for bulldozers</li> <li>Exterior linings of bulldozer buckets</li> <li>● Trailer beds</li> <li>● Vessels for dump and cargo trucks</li> <li>● Dredger buckets</li> </ul>
<p><b>Cement and Mining</b></p>	<ul style="list-style-type: none"> <li>● Lining material for ready-mixed concrete turbine mixer</li> <li>● Paddle for above</li> <li>● Conveyor chute for concrete mixing plant</li> <li>● Pug mill for soil cement</li> <li>● Conveyor pipe for solids (pneumatic pipelines for coal mines)</li> </ul>
<p><b>Chemical Industry</b></p>	<ul style="list-style-type: none"> <li>● Agitators for asphalt plants and finishers</li> <li>● Sand conveyor pipe for sand cracking in naphtha cracking plants</li> <li>● Sulfide mineral bucket elevators</li> </ul>
<p><b>Steel and Gas</b></p>	<ul style="list-style-type: none"> <li>● BF top swivel chute</li> <li>BF stationary chute, liner, upper hopper liner, gate liner</li> <li>● BF gas washing venturi scrubber, and septum valve</li> <li>● Screens for ores, and switching damper</li> <li>Bypass chute for ore conveyors</li> <li>Chute for ore conveyors</li> <li>Tripper chute for ore conveyors</li> <li>● Tripper chute for coke conveyors</li> <li>Coke conveyor chute, and stacker chute</li> <li>● Lining for rotary mixers</li> <li>● Drop chute receiver for blending conveyor in sintering plants</li> <li>Liner for vibro-feeders in sintering plants</li> <li>● Raw material and sole roll feeders</li> </ul>
<p><b>Others</b></p>	<ul style="list-style-type: none"> <li>● Earth drills</li> <li>● Shear liners</li> </ul>

# Recommendations for excellent fabrication performance

## Gas cutting

- Gas cutting can be applied in the same way as for ordinary steel plates. However, due to the hardness of JFE EVERHARD, it is necessary to prevent the “notches” that occur during gas cutting of a plate as they may cause the plate to crack.
- Therefore, higher gas pressure and oxygen pressure and lower cutting speed are preferable in order to prevent the notches.
- In particular, when cutting an ultra-hard steel plate, such as grade 500, it is recommended to preheat or postheat it at a temperature under 200°C to prevent its cracking from cut surface.
- If notches occur during the cutting of a high hardness steel plate, cracks might result. Therefore, in such cases, use a grinder or other tools to form smooth finish.
- A thin hardened layer will be formed on the gas cut surface due to heat effects, although its thickness is around 2 ~ 3mm as shown in the Fig. 1. A softening layer appears next to a hardening layer due to heating by gas cutting.

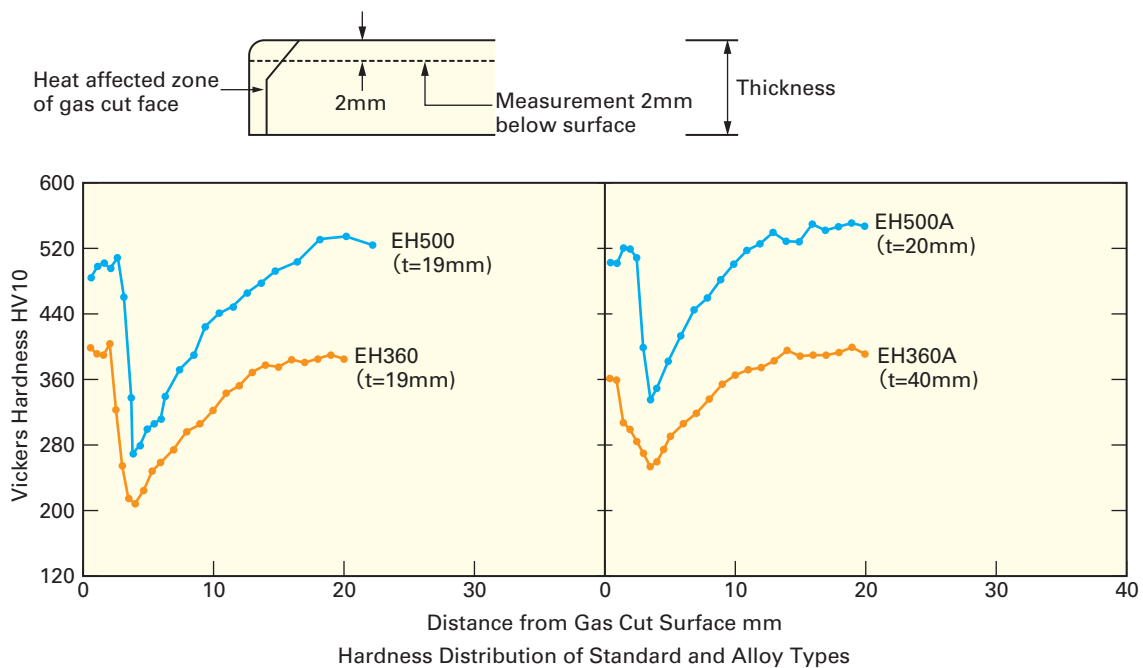

**Fig. 1 Hardness around gas cut surface**

- In case the surface temperature increases above 250°C by such operations as gas cutting into small pieces, please note that there is a possibility of hardness reduction.
- Surface temperature will be elevated too high if simultaneous cutting of both the sides is carried out when slitting especially into small pieces. In such cases, please cut one side first and wait for the cooling of the surface temperature sufficiently, then cut another side. Please use caution with hardness reduction near gas cut surface as shown in Fig. 1, especially when slit pieces for applications or hardness test are taken.



**Recommendations  
for excellent fabrication performance**



**Machining**

- For machining tools, super-hardened tools are recommended.
- The machining conditions will vary according to the hardness level of a steel plate, the tool and cutting method used, etc. As the hardness level increases, it becomes necessary to reduce the cutting depth and feed speed.
- For EH-SP, the same machining tools as that for EH500 are applicable.

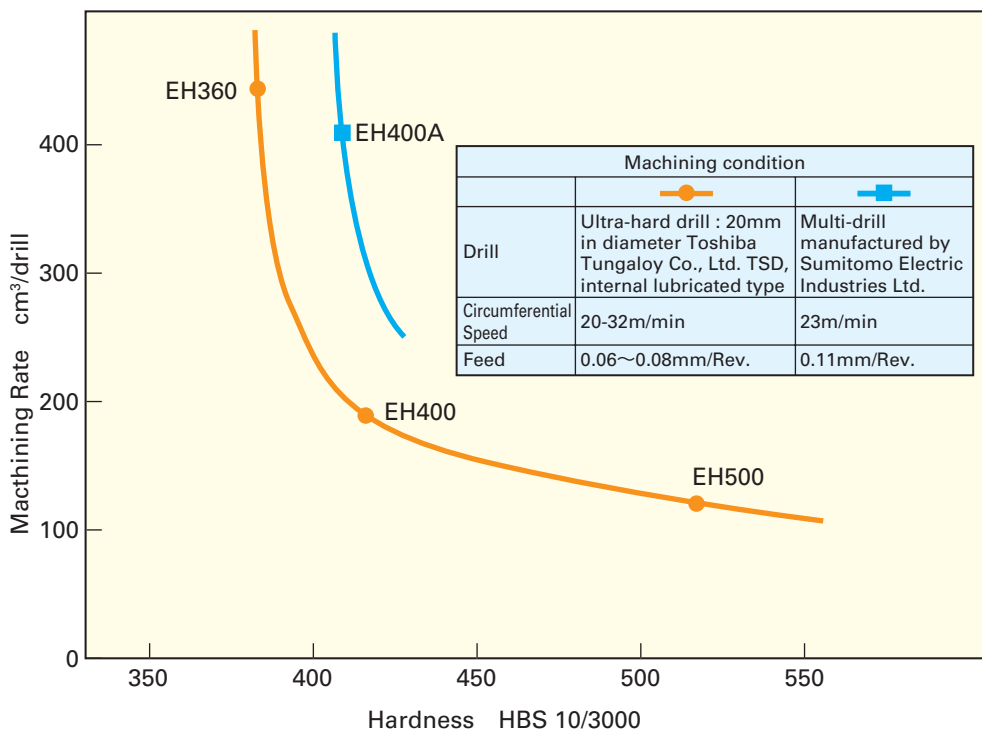

**Fig. 2 Machining rate according with hardness**

## Shot blasting

- When shot blasting is required, it is recommended to be applied after cold working. Although the increment of hardness by blasting is minimal.

## Bending

- JFE EVERHARD is formable by cold working such as pressing or roll bending. However, more care is necessary than with high strength steel due to its high hardness.
- Bending radius more than that are shown in Table 1 is recommended. However the removal of the notches on the cut surface, and the adequate rounding of the edge corner are necessary. To secure the bending, the removal of a hardened layer produced by flame cutting is recommended.
- Bending or roll forming is preferable to be performed transverse to the final direction of rolling as shown in Fig. 3.
- In order to prevent inside cracking, overbend by forming with small radius die, such as pipe forming, is not recommended.
- Since fragments of materials might fly about when crack occurs on the plate during processing of bending especially high hardness material such as 500 grade, please keep enough distance from a bending machine for safety.

**Table 1 Recommended bending radius**

Grade	Minimum Bending Radius
JFE-EH360	4.5t
JFE-EH360A, EH360LE	4.5t
JFE-EH400	5t
JFE-EH500, EH500A, EH500LE	6t
JFE-EH-SP	6t

t: plate thickness

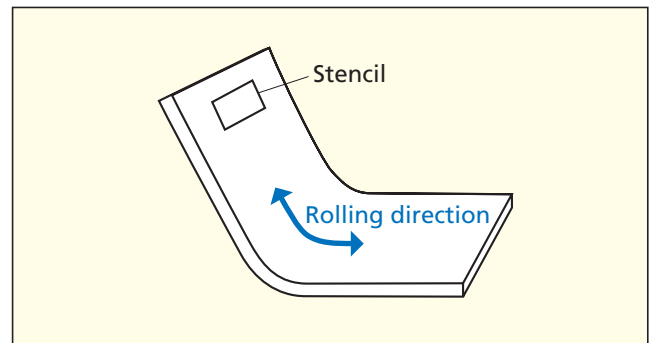

**Fig. 3 Recommended bending direction**



## Hot working

- All JFE EVERHARD grades are given by a special controlled heat treatment. Therefore, please avoid using hot working.

## Welding

- Careful cautions are required in welding of JFE EVERHARD from a viewpoint of prevention of weld cracking, as it has high hardness and high strength compare to common structural steel plates. The cracking, in many cases, is so called hydrogen induced cracking, which is also called cold cracking or delayed cracking, due to the hydrogen contained in weld metal diffusing into base metal. Therefore, please pay full attention to the following points.

### 1. Selection of welding materials

- Typical welding materials for JFE-EVERHARD are shown in Table 2.

Low hydrogen or ultra-low hydrogen type materials are recommended.

Solid wire for CO<sub>2</sub> gas shield arc welding is also recommended.

Probability of cold cracking (hydrogen induced cracking) is reduced when low strength welding materials are used. If wear resistance of weld metal is a key factor, please use high strength welding materials for final welding layers, such as 590N/mm<sup>2</sup> or 780 N/mm<sup>2</sup> grade welding material.

**Table 2 Examples of welding materials**

Materials applicable to all grades of JFE-EH in terms of weldability

Strength grade of materials	Shield metal arc welding		Gas shielded arc welding	
	Bland*	AWS grade	Bland*	AWS grade
490N/mm <sup>2</sup>	KS-76	E7016	KC-50(CO <sub>2</sub> )	ER70S-G
	KSA-76	E7016-G	KM-50(Ar + CO <sub>2</sub> )	ER70S-G
	LB-52	E7016	MG-50(CO <sub>2</sub> )	ER70S-G
	LB-52UL	E7016	MGS-50(Ar + CO <sub>2</sub> )	ER70S-G
590N/mm <sup>2</sup>	KSA-86	E9016-G	KC-60(CO <sub>2</sub> )	ER80S-G
	LB-62	E9016-G	MG-60(CO <sub>2</sub> )	ER80S-G
	LB-62UL	E9016-G	MGS-63B(Ar + CO <sub>2</sub> )	ER90S-G
780N/mm <sup>2</sup>	LB-116	E11016-G	MGS-80(Ar + CO <sub>2</sub> )	ER110S-G
	LB-80UL	E11016-G		

\*JFE Steel Corp. or KOBELCO

## Recommendations for excellent fabrication performance

### 2. Preheating

- Preheating condition varies with chemical composition, plate thickness and the restraint conditions for weld areas. For your reference, recommended preheating temperature based on test results under high restraint condition is given in Table 3.
- In case preheating can not be applied, it can be welded by using austenitic stainless materials. In this case, high Cr and Ni content austenitic stainless material such as type 309 is recommended instead of 304 or 316 type.

### 3. Postheating

- In general, postheating is not necessarily required unless hard facing welding material is used. Postheating at the same temperature as preheating makes crack prevention more secure.

**Table 3 Recommended preheating temperature**

Based on y-groove weld cracking test results under high restraint

Grade	Thickness mm	Shielded metal arc welding <sup>*1</sup> (°C)	Gas shielded arc welding <sup>*2</sup> (°C)
JFE-EH360LE	19	75	25
	32	100	25
JFE-EH360	19	75	50
	40	125	100
JFE-EH400	20	100	50
	40	175	100
JFE-EH500LE	19	125	75
	32	175	125
JFE-EH500	19	125	75
	40	175	125
JFE-EH360A	20	100	75
	40	150	125
JFE-EH500A	20	125	100
	40	175	150
JFE-EH-SP	35	175	175
	51	200	200

\*1 Welding materials : LB-62(AWS E9016-G)

\*2 Welding materials : MG-50(AWS ER70S-G)

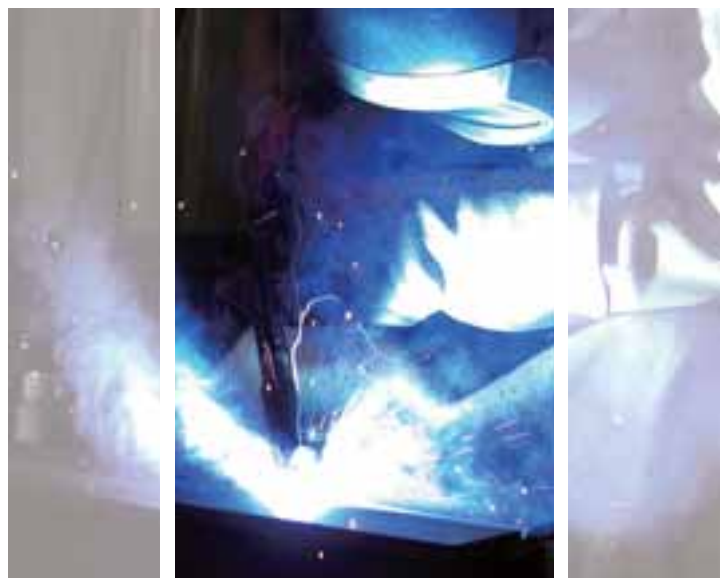

#### 4. Other general items

- Before using welding electrodes, please re-dry them for shield metal arc welding at 350 ~ 400°C for approximately 1 hour.
- When flux cored wire is used, please note that induced hydrogen might be higher by moisture absorption of flux. The stocking procedures of FCW shall be in accordance with the suppliers' instruction.
- When humidity at working area is high, induced hydrogen might be high. The stocking procedures of FCW shall be in accordance with the suppliers' instruction.
- Please remove rust, oil, slag and other undesirable materials from the weld area and maintain it in good condition. Such contaminations might provide weld defects and/or cracking.
- If arc-striking is done on the surface of the base metal, it may cause cracks. Therefore, use either the back-step welding or waste piece arcing method.
- Please keep the arc length as short as possible.
- Please avoid weaving as much as possible. If weaving must be performed, please restrict it to no more than 1.5 times the diameter of the welding electrode.
- Tack welding can be performed in the same manner as conventional welding, however please keep the bead length 50mm or longer.
- Heat input is recommended to be set above 2kJ/mm.

#### PWHT

- PWHT is sometimes applied to structures such as pressure vessels to reduce residual stress by welding. However PWHT should not be applied to JFE-EVERHARD used for wear resistant purpose.

## Storage

- For storing plates, deflection and distortion of plates should be minimized, and the plates have to be waterproofed by sheet to prevent rusting and pitting by corrosion from which crack would be originated. When a waterproof sheet is used, it should be removed away occasionally to reduce inside humidity.

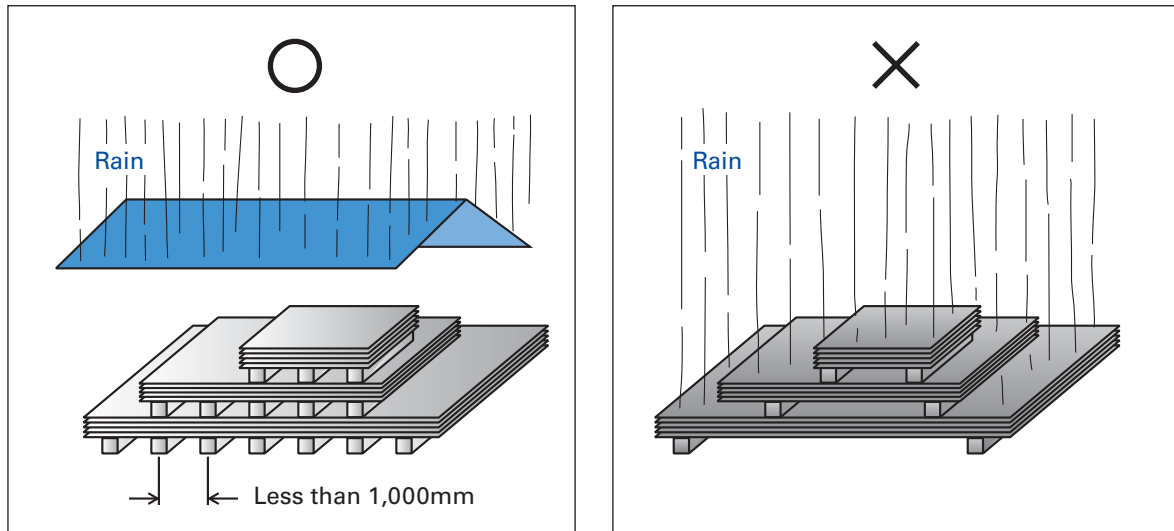

**Fig. 4 Recommended storage method**

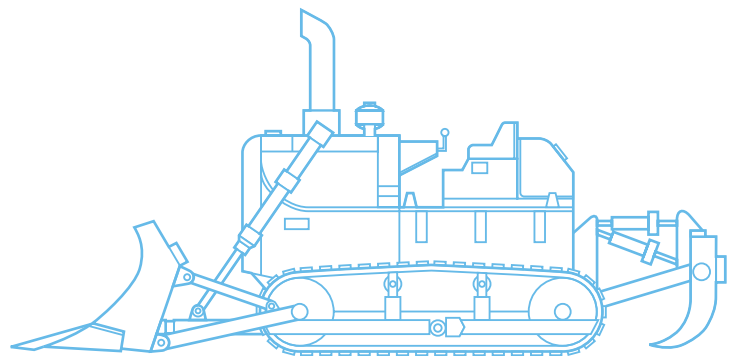

**JFE Steel Corporation**<http://www.jfe-steel.co.jp/en/>

---

<b>TOKYO HEAD OFFICE</b>	Hibiya Kokusai Building, 2-3 Uchisaiwaicho 2-chome, Chiyodaku, Tokyo 100-0011, Japan Phone : (81)3-3597-3111 Fax : (81)3-3597-4860
<b>NEW YORK OFFICE</b>	JFE Steel America, Inc., New York Office 350 Park Avenue, 27th Fl., New York, NY 10022, U.S.A. Phone : (1)212-310-9320 Fax : (1)212-308-9292
<b>HOUSTON OFFICE</b>	JFE Steel America, Inc., Houston Office 10777 Westheimer, Suite 1010 Houston, TX 77042, U.S.A. Phone : (1)713-532-0052 Fax : (1)713-532-0062
<b>BRISBANE OFFICE</b>	JFE Steel Australia Resources Pty Ltd. Level 19, CPA Centre, 307 Queen St, Brisbane, QLD 4001, Australia Phone : (61)7-3229-3855 Fax : (61)7-3229-4377
<b>RIO DE JANEIRO OFFICE</b>	JFE Steel do Brasil LTDA, Rio de Janeiro Office Praia de Botafogo, 228 Setor B, Salas 508 & 509, Botafogo, CEP 22359-900, Rio de Janeiro-RJ, Brazil Phone : (55)21-2553-1132 Fax : (55)21-2553-3430
<b>LONDON OFFICE</b>	JFE Steel Corporation, London Office 8th Floor, International Press Centre, 76 Shoe Lane, London EC4A 3JB, U.K. Phone : (44)20-7583-1133 Fax : (44)20-7583-1144
<b>NEW DELHI OFFICE</b>	JFE Steel India Private Limited 1101, 11th Floor, Unitech's Signature Tower, Tower-A, South City-I, NH-8, Gurgaon, Haryana, 122002, India Phone : (91)124-426-4981 Fax : (91)124-426-4982
<b>SINGAPORE OFFICE</b>	JFE Steel Asia Pte. Ltd. 16 Raffles Quay, No. 15-03, Hong Leong Building, 048581, Singapore Phone : (65)6220-1174 Fax : (65)6224-8357
<b>BANGKOK OFFICE</b>	JFE Steel Corporation, Bangkok Office 22nd Floor, Abdulrahim Place 990, Rama IV Road, Bangkok 10500, Thailand Phone : (66)2-636-1886 Fax : (66)2-636-1891
<b>JAKARTA OFFICE</b>	JFE Steel Corporation, Jakarta Office 15th Floor Summitmas II, JL Jendral Sudirman Kav. 61-62, Jakarta 12190, Indonesia Phone : (62)21-522-6405 Fax : (62)21-522-6408
<b>MANILA OFFICE</b>	JFE Steel Corporation, Manila Office 23rd Floor 6788 Ayala Avenue, Oledan Square, Makati City, Metro Manila, Philippines Phone : (63)2-886-7432 Fax : (63)2-886-7315
<b>SEOUL OFFICE</b>	JFE Steel Korea Corporation 6th Floor. Geumgang-Tower. 889-13, Daechi-dong, Gangnam-gu, Seoul, 135-570, Korea Phone : (82)2-3468-4130 Fax : (82)2-3468-4137
<b>BEIJING OFFICE</b>	JFE Steel Corporation, Beijing Office 1720 Beijing Fortune Building No.5, Dongsanhuan North Road, Chaoyang District, Beijing, 100004, P.R.China Phone : (86)10-6590-9051 Fax : (86)10-6590-9056
<b>SHANGHAI OFFICE</b>	JFE Consulting (Shanghai) Co., Ltd. Room No.2112, Lippo Plaza, 222 Huai Hai Road(M), Shanghai 200021, P.R.China Phone : (86)21-5396-5610 Fax : (86)21-5396-5611
<b>GUANGZHOU OFFICE</b>	JFE Consulting (Guangzhou) Co., Ltd. Room 3901, Citic Plaza, 233 Tian He North Road, Guangzhou 510613, P.R.China Phone : (86)20-3891-2467 Fax : (86)20-3891-2469

**Notice**

While every effort has been made to ensure the accuracy of the information contained within this publication, the use of the information is at the reader's risk and no warranty is implied or expressed by JFE Steel Corporation with respect to the use of information contained herein. The information in this publication is subject to change or modification without notice. Please contact the JFE Steel office for the latest information.